



Reliable Food-Safe Scale for Dry Environments

With a food-safe design that is NSF certified, the Valor 1000 series is a reliable choice for general food weighing. Easy-to-operate, Valor 1000 scales feature two-button operation, large backlit LCD display and up to 1,500-hour battery life.

Standard Features:

- **Easy-Clean, Hygienic Design**
NSF-listed design supports HACCP systems with durable ABS housing and removable stainless steel pan, making Valor 1000 suitable for food preparation and portioning applications.
- **Low Power Consumption Design Promotes Continuous Use**
Save money on batteries. Energy-efficient design operates for up to 1,500 hours.
- **Easy Two-Button Operation**
Intuitive two-button operation allows for quick weight checking to simplify repetitive operations and increase operator efficiency.

VALOR®1000 - V12P Compact Bench Scales

Model	V12P3	V12P6	V12P15	V12P30
Capacity × Readability (Max x d non-approved)	3 kg x 0.0005 kg 3,000 g x 0.5 g	6 kg x 0.001 kg 6,000 g x 1 g	15 kg x 0.002 kg 15,000 g x 2 g	30 kg x 0.005 kg 30,000 g x 5 g
Maximum Displayed Resolution	1 : 6,000	1 : 6,000	1 : 7,500	1 : 6,000
Weighing Units	g, kg, lb, oz, lb:oz			
Application Mode	Weighing			
Tare Range	To capacity by subtraction			
Stabilization Time	≤ 2 seconds			
Power Requirements	Four Type D Alkaline batteries (included), AC adapter or rechargeable battery kit (optional)			
Calibration	Digital with external weight			
Battery Life	1,500 hours (with backlight turned off)			
Construction	ABS plastic housing and stainless steel pan			
Safe Overload Capacity	150% of capacity			
Specified Temperature Range	0 to 40 °C			
Display	Single display - LCD with white backlight			
Display Size	25.4 mm			
Pan Size	245 x 190 mm			
Scale Dimensions (W x D x H)	260 x 270 x 122 mm			
Shipping Dimensions (W x D x H)	319 x 319 x 175 mm			
Net Weight	2.5 kg			
Shipping Weight	3.1 kg			

Other Standard Features and Equipment

Digital with external weight , Integrated level bubble and adjustable feet, selectable Auto-Off, selectable weighing units and integrated carrying handles for easy transportation

Compliance

- **Product Safety:** IEC/EN 61010-1; UL certified power supply
- **Electromagnetic Compatibility:** EN/IEC 61326-1 Class B, Basic environments
- **Food Equipment:** ANSI/NSF 169
- **Compliance Marks:** CE; NSF; WEEE

Accessories

Rechargeable Battery Kit	30559104	Adapter, 10W, 12DVC, Main Body	46001812
In-use Cover (1)	30559105	EU-UK Plug	46001779
In-use Cover (10)	30559106	Stainless Steel Platform, 300 x 225 mm	30559107

Outline Dimensions

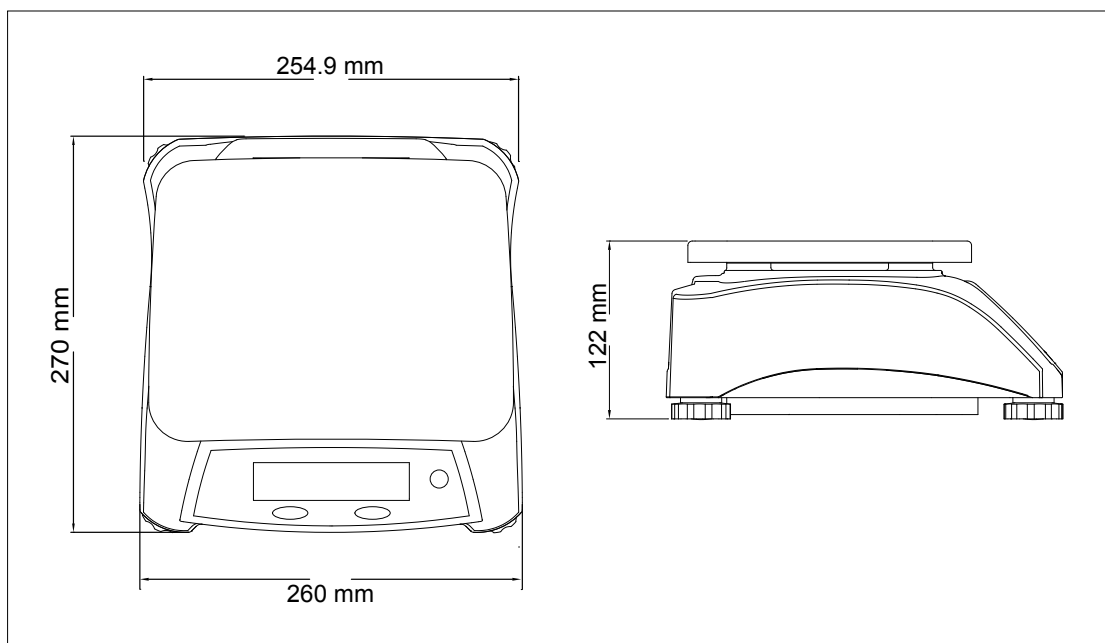

OHAUS Europe GmbH
Heuwinkelstrasse 3,
8606 Nänikon,
Switzerland

e-mail: ssc@ohaus.com
Tel: 0041 22 567 53 19
e-mail: tsc@ohaus.com
Tel: 0041 22 567 53 20

www.ohaus.com

The management system
governing the manufac-
ture of this product is ISO
9001:2015 certified.

CH16G014

